

# RGB

SERIES

## INSTANTANEOUS BISTABLE (LATCHING) RELAYS WITH 3-4 CHANGE-OVER CONTACTS

### APPLICATIONS



Shipbuilding



Petroleum industry



Heavy industry



Power generation



Power distribution



Railway equipment



RGBE13



RGBE14

### OVERVIEW

- Solid and rugged construction for intensive duty
- Knurled, self-cleaning C/O contacts
- High electrical life expectancy
- Maximum continuous current 12 A
- Magnetic arc blower for improved breaking capacity
- Optical contact status indicator included
- Cover with matte finishing, pull-out handle
- Positive mechanical keying for relay and socket

### DESCRIPTION

Available with **4 C/O + 1 NO or NC** contact as option. Highly reliable together with high performance, suitable for applications in very **harsh and perturbed environments**, such as per electrical stations.

The mechanical design allows the development of **custom solutions**, in the event that the standard models do not fully respond to the required parameters.

Wide range of coil's nominal voltage: the manufacturing versatility allows to adapt power supply to customer needs.

Contacts are designed to obtain **remarkable performances both for high and low currents, inductive loads or very low loads** (10mA - 10V at new relay).

The **contacts' knurled surface** ensures an **excellent self-cleaning action**, the particular shape also lower the ohmic resistance thanks to the various points of electrical contact.

The magnetic **arc blower** contributes to increase breaking capacity: the relay is suitable for controlling heavy duty loads with intensive switching frequency.

**Options:** manual set-reset, flyback diode, led and gold plated contacts etc.

A wide range of sockets allow to find the optimal solutions for any electrical panel's construction need.

As per all AMRA relays, RGM relays are assembled under controlled manufacturing process in which every step of production is verified by the next step in succession.

**Each relay are carefully tested** at the end of production.

These range of components have two stable states, i.e., they are able to hold their position in the event of a power supply failure, thereby guaranteeing that this can be stored as "memory" information.

Given their superior reliability and durability, RGB relays are capable of filling roles that require a high level of responsibility; they are used for example as lock-out relays in environments where continuous duty is essential (e.g. high voltage electricity distribution stations and medium voltage substations).

All models are equipped with an automatic coil de-energization system, operated mechanically or electronically, designed to reduce the power consumption of the device to zero once the operating cycle is completed.

### STANDARD COMPLIANCY

EN 60695-2-10  
EN 60529

EN 61810-1  
EN 61810-2  
EN 61810-7



MODELS	NUMBER OF CONTACTS	POWER INPUT TO COILS
RGBE.x3	3	Common negative
RGBE.x4	4	Coils galvanically separated



**FOR PRODUCT CODE CONFIGURATION, SEE THE "ORDERING SCHEME" TABLE**



### COIL DATA

Nominal voltages at Un <sup>(1)</sup>	DC / AC: 12 - 24 - 48 - 110 - 125 - 132 - 144 - 230 - 250 - 380 <sup>(2)</sup> - 440 <sup>(2)</sup>
Consumption at Un <sup>(3)</sup>	15 W / 15 VA
Operating range	80..120% Un
Type of duty	Continuous

Minimum control pulse 50ms

(1) Other values on request

(2) Maximum value, AC = 380V 50Hz - 440V 60Hz

(3) Only on latch and unlatch stage. After relay switching, power consumption is zero, as the coil de-energizes automatically



### CONTACT DATA

Number and type	<b>3 o 4 SPDT, form C</b>		
Current	Nominal <sup>(1)</sup>	12A	
	Maximum peak <sup>(2)</sup>	20A for 1min - 40A for 1s	
	Maximum pulse <sup>(2)</sup>	150A for 10ms	
Example of electrical life expectancy <sup>(3)</sup>	0.5A - 110Vdc - L/R 40ms - 10 <sup>5</sup> operations - 1,200 operations/hour		
Minimum load <sup>(4)</sup>	Standard contacts	200mW (10V, 10mA)	
	Gold-plated contacts <sup>(5)</sup>	50mW (5V, 5mA)	
Maximum breaking voltage	350 VDC / 440 VAC		
Contact material	AgCdO		
Operating time at Un (ms) <sup>(6)</sup>		<b>RGB.13-33-43</b>	<b>RGB.14-34-44</b>
		DC - AC	DC - AC
	Pick-up (NC contact opening)	≤ 9 - ≤ 20	≤ 9 - ≤ 20
	Pick-up (NO contact closing)	≤ 30 - ≤ 35	≤ 30 - ≤ 35
	Drop-out (NO contact opening)	≤ 7 - ≤ 21	≤ 7 - ≤ 21
	Drop-out (NC contact closing)	≤ 45 - ≤ 65	≤ 45 - ≤ 55

(1) On all contacts simultaneously, reduction of 30%

(2) Maximum peak and pulse currents are those currents that can be handled, for a specified time, by the contact. They do not refer to steady or interrupted currents

(3) For other examples, see electrical life expectancy curves

(4) Values referred to a new product, measured in laboratory. The ability to maintain this performance over the time depends on the environmental conditions and the contact' frequency use  
The use of gold plated contacts is recommended in the case of very low loads. For a correct contact use, refer to the chapter "Installation, operation and maintenance".

(5) A gold contact, if subjected to high loads, degrades superficially. In this case, the characteristics of the standard contact must be considered. This does not affect the operation of the relay

(6) Unless specified otherwise, operating times are understood as comprising stabilization of the contact (inclusive of bounces)



### INSULATION

Insulation resistance (at 500Vdc) between electrically independent circuits and between these circuits and ground between open contact parts	> 10,000 MΩ > 10,000 MΩ
Withstand voltage at industrial frequency between electrically independent circuits and between these circuits and ground between open contact parts between adjacent contacts	2 kV (1 min) - 2.2 kV (1 s) 2 kV (1 min) - 2.2 kV (1 s) 2 kV (1 min) - 2.2 kV (1 s)
Impulse withstand (1.2/50μs - 0.5J) between electrically independent circuits and ground between open contact parts	5 kV 5 kV



### MECHANICAL SPECIFICATIONS

Mechanical life expectancy	20x10 <sup>6</sup> operations	
Maximum switching rate	900 operations/hour	
Degree of protection	IP40	
Dimensions (mm)	45x50x86 <sup>(1)</sup>	45x50x112 <sup>(1)</sup>
	Weight (g)	270

(1) Output terminals excluded.

## ENVIRONMENTAL CHARACTERISTICS



Operating temperature	-25 ÷ +55°C
Storage and shipping temperature	-25 ÷ +70°C
Relative humidity	Standard: 75% RH - Tropicalized: 95% RH
Fire behaviour	V0

## STANDARDS AND REFERENCE VALUES



EN 61810-1, EN 61810-2, EN 61810-7	Electromechanical elementary relays
EN 60695-2-10	Fire behaviour
EN 60529	Degree of protection provided by enclosures

Unless otherwise specified, the products are designed and manufactured according to the requirements of the above-mentioned European and International standards.

In accordance with EN 61810-1, all technical data are referred to ambient temperature of 23°C, atmospheric pressure of 96kPa and 50% humidity.

Tolerance for coil resistance and nominal power is ±7%.

## CONFIGURATIONS - OPTIONS



<b>TROPICALIZATION</b>	Surface treatment of the coil with protective coating for use with RH 95%.
<b>GOLD PLATING</b>	Surface treatment of the contacts, with gold-cobalt alloy ≥ 5µ (since 2023, May). This treatment ensures long-term ability of the contact to conduct lower currents.
<b>FLYBACK DIODE</b>	Component connected in parallel to the coil designed to dampen overvoltages generated by the coil when de-energized.
<b>LEVER FOR MANUAL OPERATION</b>	Allows manual operation of the relay, with the cover closed, using a screwdriver.

## ORDERING SCHEME



PRODUCT CODE	APPLICATION <sup>(1)</sup>	CONFIGURATION A	CONFIGURATION B	TYPE OF POWER SUPPLY	NOMINAL VOLTAGE (V) <sup>(2)</sup>	FINISH <sup>(3)</sup>	KEYING POSITION CODE <sup>(4)</sup>
RGB	E: Energy	1: Standard	3: 3 SPDT contacts	C: Vdc	012 - 024 - 048	T: Tropicalized coil	XX
	F: Railway Fixed equipment	3: Diode //	4: 4 SPDT contacts	A: Vac 50 Hz	110 - 125 - 132	M: Manual operation <sup>(5)</sup>	
		4: Gold plating		H: Vac 60 Hz	144 - 220 - 230		
		6: Gold plating + Diode //			250 - 380 - 440		

Example	RGB	E	3	3	C	048	T	
	RGBE33-C048/T = ENERGY series relay with 3 SPDT contacts, flyback diode and 48Vdc tropicalized coil.							
	RGB	F	1	4	C	110		SBH
	RGBF14-C110-SBH = RAILWAY series relay, fixed equipment, with 4 SPDT contacts, 110VDC coil and keying position SBH.							

- ENERGY:** All applications except for railway.  
**RAILWAYS, FIXED EQUIPMENT:** application on fixed power systems and electrical railway traction.  
For list of RFI compliant and type-approved products, consult dedicated catalogue "RAILWAY SERIES - RFI APPROVED".  
Also available is the **STATIONS** series, with ENEL approved material meeting LV15/LV16 specifications.  
For list of ENEL compliant and type-approved products, consult dedicated catalogue "STATIONS SERIES - LV15-LV16-LV20"
- Other values on request. Voltages 380V and 440V available as Vac only.
- Optional value. Multiple selection possible (e.g. TM).
- Option value. The positive mechanical keying is applied according to the manufacturer's model.
- With manual operation, no optical indicator.



## WIRING DIAGRAM

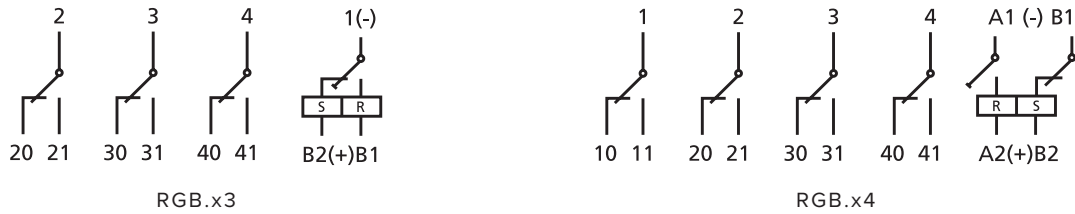

### NOTE:

Coils nomenclature change from 2024/05

**S** = SET (it was C)

**R** = RESET (it was S)



## DIMENSIONS

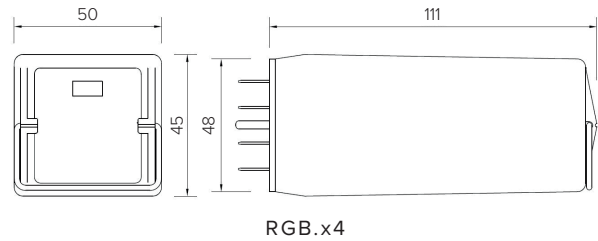
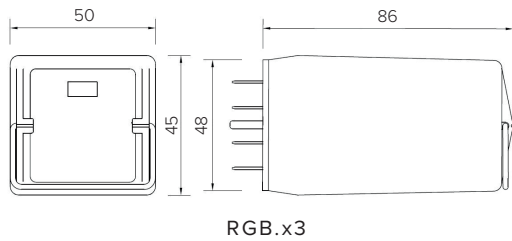

## ELECTRICAL LIFE EXPECTANCY

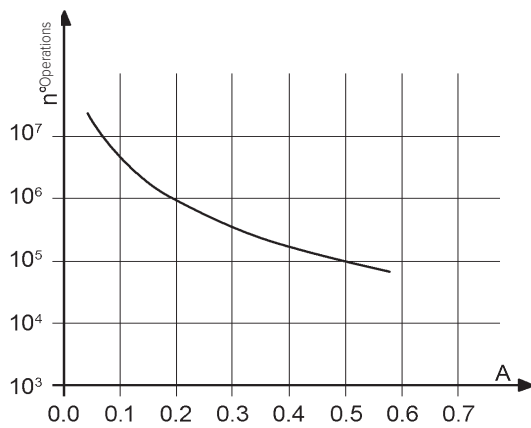

Contact loading: 110Vdc, L/R 40 ms

U	I (A)	L/R (ms)	Operations
110Vdc	0.5	40	100,000
110Vdc	0.6	10	300,000
120Vdc	0.7	40	50,000
125Vdc	1.2	0	1,000,000
220Vdc	0.1	40	100,000
220Vdc	0.25	10	100,000
U	I (A)	cosφ	Operations
110Vac	1	1	2,000,000
110Vac	1	0.5	1,500,000
110Vac	5	1	1,000,000
110Vac	5	0.5	500,000
220Vac	0.5	1	2,000,000
220Vac	1	0.5	600,000
220Vac	5	1	650,000
220Vac	5	0.5	600,000

Switching frequency: 1,200 operations/hour



## SOCKETS AND RETAINING CLIPS

SOCKETS AND RETAINING CLIPS			RGBE.x3	RGBE.x4
Type of installation	Type of outputs	Model	Retaining clip	
Wall or DIN rail mounting	Screw	PAVG161	VM1221	VM1222
Flush mounting	Double faston (4.8 x 0.8 mm)	PRDG161		
	Screw	PRVG161		



## INSTALLATION, OPERATION AND MAINTENANCE

### Installation

Before installing the relay on a wired socket, disconnect the power supply.

The preferential mounting position is on the wall, with the relay positioned horizontally in the "reading orienting" of marking.

Spacing: no relay spacing is required.

## Operation

**Before use:** if relay is not used, for example after long storage periods, contact resistance may increase due to a natural and slight oxidation or polluting deposits.

In order to restore the optimal conductivity and for standard contacts (**NOT gold plated**) it is recommended to switch several time a load of at least 110Vdc - 100mA or 24Vdc - 2A. The contacts will be "cleaned" thanks to the electric arc generated during the current interruption and the mechanical self-cleaning action.

The common contact rubs against the fixed poles (NO and NC contacts) both when opening and when closing, which ensures a self-cleaning action.

An increase in contacts' resistance, in most cases, does not represent a problem. Many factors contribute to the correct use of contact and consequently to the relay' long-term reliability:

- **Load:** the current switching generates an electric arc with cleaning effects. For proper electrical cleaning and performance keeping we recommend:
  - Standard contacts: Minimum current = 20mA (20V)
  - Gold plated contacts: Minimum current = 10mA (20V)
- **Operating frequency:** relays are components that can operate with a wide range of switching frequency. High frequency operation also allows a continuous cleaning effect by "sliding" (mechanical cleaning). In case of low frequency operation (for example few time a day), we advise:
  - Use of contact with currents twice compared to those indicated.
  - For currents lower than 10mA, use gold plated contacts and connect 2 contacts in parallel, in order to reduce the equivalent contact resistance
- **Pollution:** the presence of pollution can cause impurities on contact surface. Electric charges attract organic molecules and impurities that are deposited on the contact surface. Electrical and mechanical cleaning, respectively, burn and remove such impurities. In pollution presence, the minimum recommended currents must be respected. In extreme cases, provide double the cleaning current.

While a contact open high loads, impurities develop inside the relay due to the formation and interruption of the electric arc. These impurities are greater the higher the load and the more frequent the switching operation. These impurities could deposit on the adjacent contacts and alter the initial conductivity characteristics. If all contacts are used with similar loads, this is not a problem. Please, contact AMRA for further informations.

Condensation is possible inside the relay when energized and the outside ambient temperature is cold; this is quite normal and does not affect the operation of the relay. Plastic materials of relay do not possess hygroscopic properties.

## Maintenance

No maintenance is required.

In case of normal relay wear (reaching the end of electrical or mechanical life), the relay cannot be restored and must be replaced.

To check the component, relay removal must be carried out with slight lateral movements. An "up and down" movement can cause terminals damage.

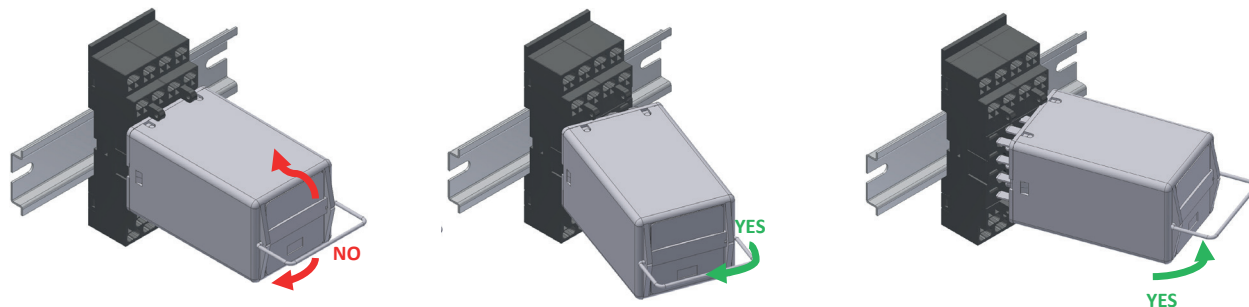

Often the malfunctions are caused by power supply with inverted polarity, by external events or by use with loads exceeding the contact performance.

In case of suspected malfunction, energize relay and observe if mechanical operation of contacts / relay mechanism is performed. Pay attention to the power supply polarity, if relay is equipped with polarized components (example: diode, led).

- In case of expected operation, clean the contacts (see paragraph "OPERATION") and check if the circuit load ranges within the contact performance. If necessary, replace with relays with gold contacts. Note: the electrical continuity of contacts must be checked with adequate current.
- If it does not work, we recommend to use a relay of the same model and configuration.

If an investigation by AMRA is required, pull-out the relay from the socket, don't remove the cap, avoid any other manipulation and contact us. You will be asked for the following data: environmental conditions, power supply, switching frequency, contact load, number of operations performed.

The fault can be described through the "TECHNICAL SUPPORT" section of the website [www.amra-chauvin-arnoux.it](http://www.amra-chauvin-arnoux.it).

In any case, the relay cannot be repaired by the user.

## Storage

Storage conditions must guarantee the environmental conditions (temperature, humidity and pollution) required for the product conservation, in order to avoid deterioration.

The product must be stored in an environment sheltered from atmospheric agents and not polluted, with an ambient temperature between -25 and +70°C with max 75% RH. Humidity can reach peaks of 95%. In any case, there must be no condensation. Before use, please read carefully "OPERATION" section.